

# ORBIWELD 38S, 76S, 115S

## Enclosed orbital weld heads

Easier to handle, more economical, more effective - enclosed TIG orbital welding heads with outstanding characteristics: The ORBIWELD "S" series from Orbitalum convinces by its extremely narrow design and high durability by its efficient integrated liquid cooling system.

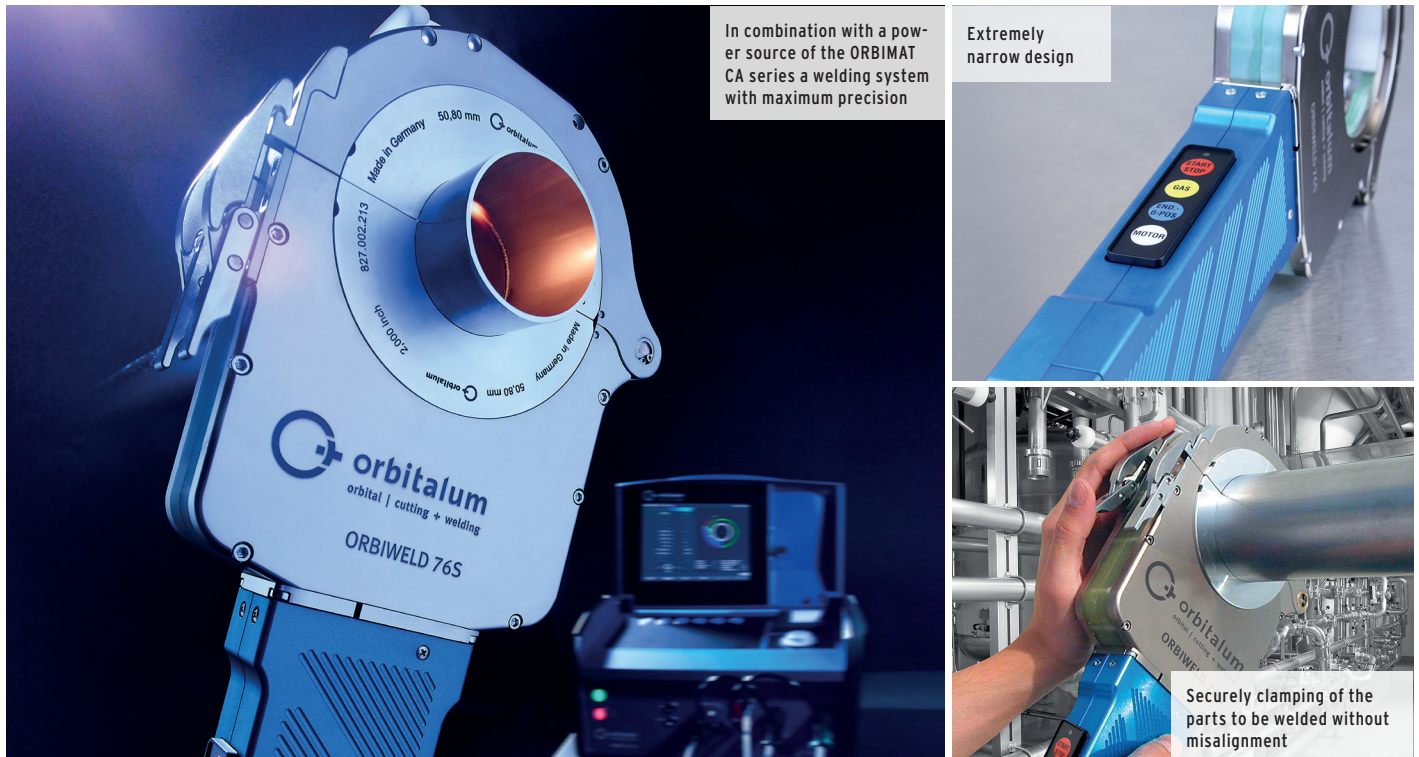

The small dimensions of the ORBIWELD "S" series make it ideal for applications where space is very restricted, such as the pharmaceutical and chemical industry, the semiconductor, food and beverage industry as well as aerospace.

All enclosed orbital weld heads of the ORBIWELD series are made from strong, durable materials of the finest quality and are characterised by their unique liquid cooling system.

The appropriate high-grade, functional and long-lasting clamping inserts are lasting longer than the inserts of many competitors. The inserts are available in small and wide design and easily and quickly insertable into the weld heads.

### ADDITIONAL FEATURES:

- Thanks to the extremely narrow design, parts with short straight welding lengths can also be processed
- High-quality, rugged housing and handle parts
- High durability due to completely liquid-cooled weld head housing
- Highly flexible hose package (Length: 7.5 m/ 24.6 ft) with strain relief to the power supply
- All the important commands for welding can be transmitted to the power supply via a control panel built into the robust and durable aluminum handle, so that no additional remote control is required
- Quick change system for clamping inserts that engages and releases smoothly without any tools

- Cost-effective clamping inserts
- Durable clamping connections in combination with clamping inserts available for all tube dimensions guarantee that the parts to be welded are clamped securely without misalignment
- Comprehensive and customer-specific range of accessories
- A folding cover at the weld head enables to test and/or to readjust the electrode position before the welding procedure

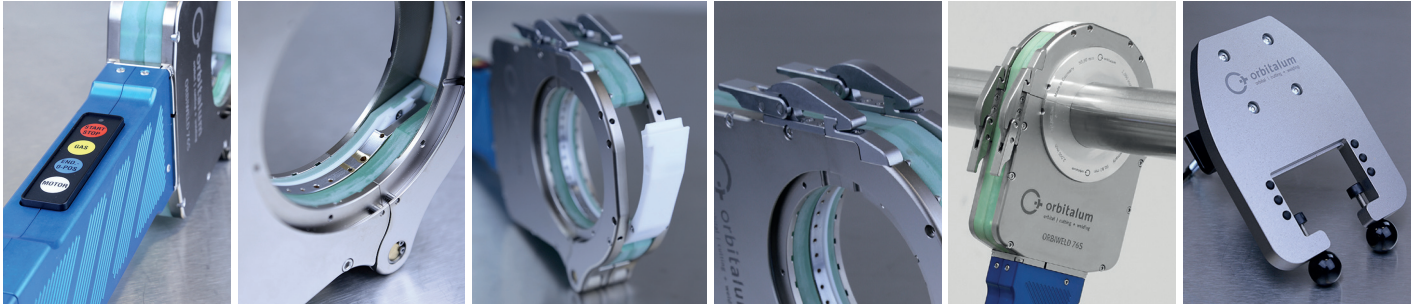

Robust and stable aluminum handle with integrated control panel

Simpler inserting of the electrodes by markings for  $\varnothing$  1.6/2.4 mm (0.063"/0.094")

Flip-up weld head cover "FlipCover"

Durable clamping connections

Diameter-specific clamping inserts (each of 2 half-shells) aluminum available separately

Comprehensive range of accessories, e.g. table mounts

DIMENSIONS	ORBIWELD 38S				ORBIWELD 76S				ORBIWELD 115S					
	DIMENSION		ELECTRODE INTERVAL CLAMPING INSERT*		DIMENSION		ELECTRODE INTERVAL CLAMPING INSERT*		DIMENSION		ELECTRODE INTERVAL CLAMPING INSERT*			
	[MM]	[INCH]	[MM]	[INCH]	[MM]	[INCH]	[MM]	[INCH]	[MM]	[INCH]	CLAMPING INSERT* TYPE "S"		CLAMPING INSERT* TYPE "W"	
Dimension "A1"	17.00	0.669	17.50	0.689	19.00	0.748	19.00	0.748	22.75	0.896	25.00	0.984	45.75	1.801
Dimension "A2"	17.00	0.669	17.50	0.689	19.00	0.748	19.00	0.748	21.25	0.837	25.00	0.984	44.25	1.742
Dimension "B"	34.00	1.339	35.00	1.378	38.00	1.496	38.00	1.496	44.00	1.732	50.00	1.969	90.00	3.543
Dimension "C"	112.00	4.409			159.00	6.260			220.00	8.661				
Dimension "D"	47.50	1.870			67.50	2.657			104.00	4.094				
Dimension "E"	47.00	1.850			66.00	2.598			102.00	4.016				
Dimension "F"	144.00	5.669			187.00	7.362			244.00	9.606				
Dimension "G"	357.00	14.055			400.00	15.748			480.00	18.898				
Dimension "H"	95.00	3.740			135.00	5.315			208.00	8.189				
Dimension "I"	34.00	1.339			34.00	1.339			44.00	1.732				
Dimension "J"	55.00	2.165			55.00	2.165			55.00	2.165				
Dimension "K"	71.00	2.795			71.00	2.795			102.00	4.016				
Dimension "L"	110.00	4.331			153.00	6.024			216.00	8.504				

\* 2 pairs

APPLICATION RANGE	ORBIWELD 38S	ORBIWELD 76S	ORBIWELD 115S
Code	826 000 001	827 000 001	828 000 001
Tube OD, min. - max.	3 - 38.1 mm 1/8" - 1.5"	6 - 77 mm 1/4" - 3.0"	20 - 115 mm 3/4" - 4.5"
Electrode $\varnothing$	1.6/2.4 mm .063"/.094"	1.6/2.4 mm .063"/.094"	1.6/2.4 mm .063"/.094"
Machine weight including hose package	6.9 kg 15.2 lbs	7.5 kg 16.5 lbs	9.7 kg 21.4 lbs
Hose package length	7.5 m / 24.6 ft	7.5 m / 24.6 ft	7.5 m / 24.6 ft

SCOPE OF DELIVERY	
Including:	<ul style="list-style-type: none"> <li>• 1 Enclosed orbital weld head OW 38S, OW 76S or OW 115S</li> <li>• 1 Durable storage and shipping case</li> <li>• 1 Tool set</li> <li>• 1 Power connector adapter</li> <li>• 1 Feeler gauge</li> <li>• 1 Operating instructions and spare parts list</li> </ul>
Suitable accessories (available option):	<ul style="list-style-type: none"> <li>• Clamping inserts, small and wide</li> <li>• Cavity inserts for moldings</li> <li>• Inserts for elbow welding</li> <li>• T-piece clamping inserts</li> <li>• Electrode adapters</li> <li>• Table mounts</li> <li>• ESG tungsten grinders</li> <li>• ORBmax residual oxygen meter</li> <li>• ORBIPURGE forming set</li> <li>• Hose package extensions</li> <li>• WS2 tungsten electrodes</li> </ul>

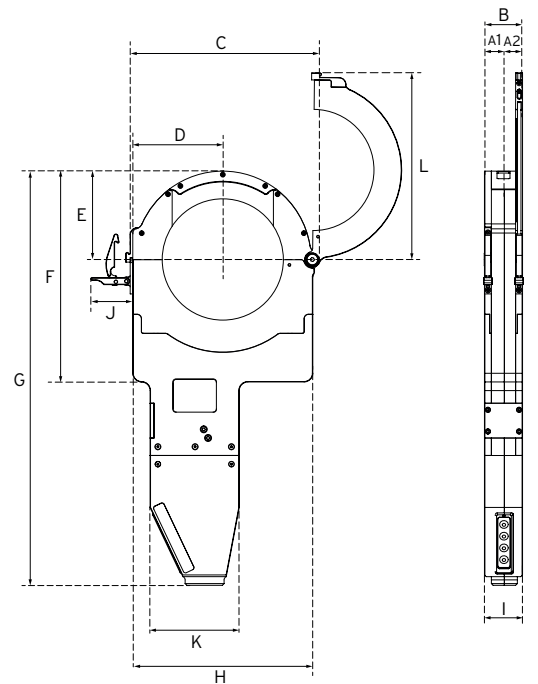

The technical data are not binding. They are not warranted characteristics and are subject to change.

